



Program summary

Workholding systems / Machine vices

Flexible workholding systems

5-axis machining

Double and multiple
workholding systems

Tower workholding systems

Concentric workholding systems

Automation

Box jaws

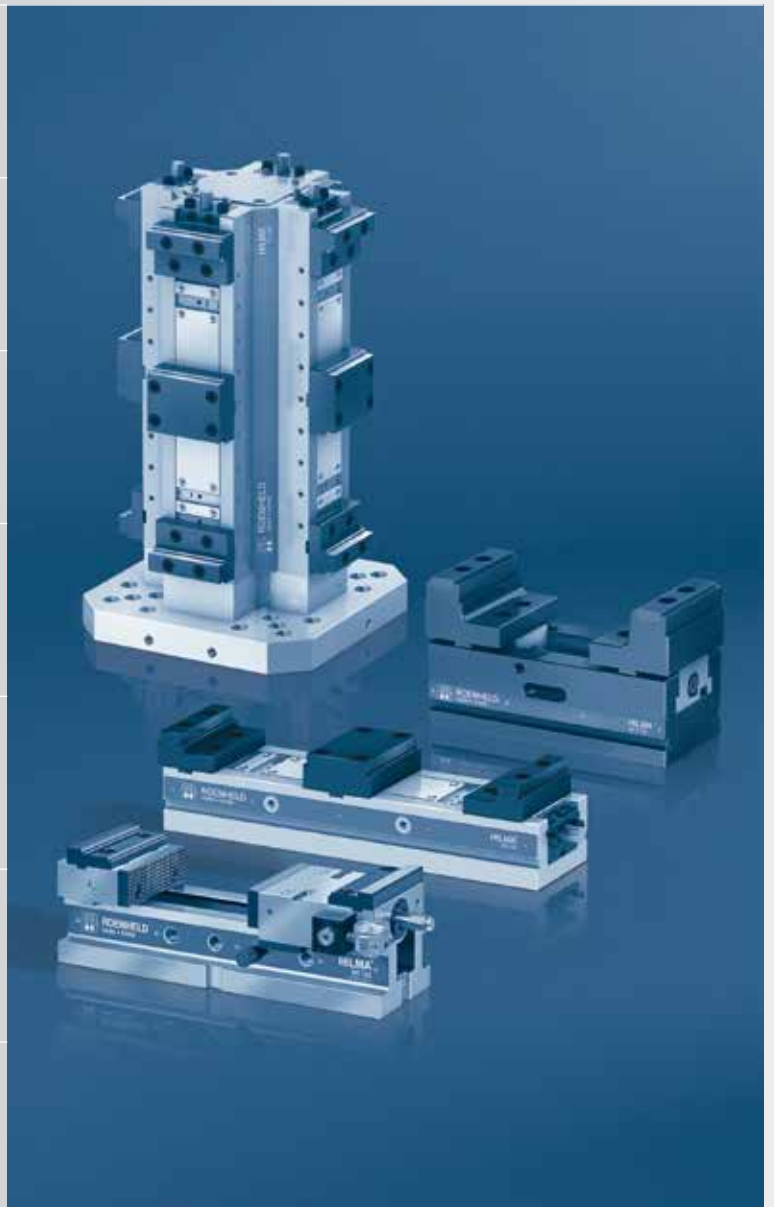







Program summary



Workholding systems / Machine vices

	Flexible workholding systems			
Series	EL	NC	VL	KNC
Data sheet	WS 1.3020	WS 1.3020	WS 2.3170	WS 1.3150
Clamping jaws /Accessories	WS 1.3020	WS 1.3020	WS 2.3170	WS 1.3150
Jaw widths (max. clamping force)	100 mm (25 kN) 125 mm (40 kN) 160 mm (50 kN)	100 mm (25 kN) 125 mm (40 kN) 160 mm (50 kN)	100 mm (25 kN) 125 mm (40 kN) 160 mm (50 kN)	100 mm (25 kN) 125 mm (40 kN) 160 mm (50 kN)
Operation				
mechanical	–	–	–	–
with hydraulic force transmission	with hydraulic force transmission	with hydraulic force transmission	with hydraulic force transmission	with hydraulic force transmission
hydraulic	–	single acting	single acting	–
Clamping principle	clamping against the fixed jaw	clamping against the fixed jaw	clamping against the fixed jaw	clamping against the fixed jaw
Application	manual loading	manual loading	manual loading	manual loading
Machining centre	vertical	vertical	vertical / horizontal	vertical / horizontal
Special features/Options	· basic system	· clamping force display · step jaw inserts	· clamping force display · variable overall length · step jaw inserts	· completely encapsulated
Overall lengths	380 ... 750 mm	380 ... 550 mm	380 ... 750 mm	300 ... 540 mm

	5-axis machining			
Series	MC-P	MC-P Z MC-P ZB	SCS	PC
Data sheet	WS 5.4501	WS 5.4502 5.4503	WS 5.3670	WS 5.3570
Clamping jaws /Accessories	WS 5.450-Z	WS 5.450-Z	WS 5.3670	WS 5.3570
Jaw widths (max. clamping force)	40 mm (7.5 kN) 60 mm (15 kN) 100 mm (25 kN) 125 mm (35 kN)	40 mm (7.5 kN) 60 mm (15 kN) 100 mm (25 kN) 125 mm (35 kN)	80 mm (25 kN) 120 mm (40 kN)	80 mm (20 kN)
Operation				
mechanical	mechanical	mechanical	mechanical	mechanical
hydraulic	on request	double acting	single acting	–
Clamping principle	clamping against the fixed jaw	concentric clamping / position flexible	clamping against the fixed jaw	clamping against the fixed jaw or concentric clamping
Application	manual loading / automation	manual loading / automation	manual loading / automation	manual loading
Machining centre	5-axis / pallets	5-axis / pallets	5-axis / pallets	5-axis / pallets
Special features/Options	· patented design · compact design	· patented design · clamping without deformation (MC-P ZB) · compact design	· covered spindle area · displaceable fixed jaw	· basic system
Overall lengths	110 ... 283 mm	110 ... 485 mm	206 ... 282 mm	170 mm





Double and multiple workholding systems

DF	DS	Duo	MSH
			
WS 3.3420 WS 3.3420	WS 3.3660/3.3680 WS 3.3660/3.3680		WS 8.3480 WS 8.3480
100 mm (25 kN) 125 mm (40 kN) 160 mm (50 kN)	100 mm (25 kN) 125 mm (40 kN)	80 mm (20 kN)	24 mm (15 kN) 40 mm (20 kN) 60 mm (25 kN) 100 mm (25 kN)
–	mechanical	mechanical	mechanical
with hydraulic force transmission	–	–	–
single acting	single acting	–	–
clamping against the fixed jaw	clamping against the fixed jaw	clamping against the fixed jaw	clamping against the fixed jaw
manual loading	manual loading / automation	manual loading / automation	manual loading
vertical	vertical/horizontal	vertical/horizontal	vertical/horizontal
<ul style="list-style-type: none"> · clamping force display · step jaw inserts · operation with 2 spindles 	<ul style="list-style-type: none"> · operation with 1 spindle · with 3rd-hand function · Vector design on request 	<ul style="list-style-type: none"> · compact workholding system 	<ul style="list-style-type: none"> · MSH variant stainless · locking via eccentric
540 ... 750 mm	420 ... 510 mm	240 mm	250 ... 750 mm

Concentric workholding systems	Automation	Box jaws
ZH	ASH	KK
		
WS 7.3540 WS 7.3540	WS 11.3100 WS 11.3100	WS 10.2060 WS 10.2060
100 mm (16 kN) 125 mm (25 kN) 160 mm (40 kN)	100 mm (25 kN) 125 mm (32 kN)	KK 150 (30 kN) KK 180 (63 kN)
–	–	mechanical
double acting	double acting	–
concentric clamping	clamping against the fixed jaw	–
manual loading / automation	manual loading / automation	manual loading
vertical / horizontal	vertical / horizontal	turning/milling centres
<ul style="list-style-type: none"> · completely encapsulated 	<ul style="list-style-type: none"> · option: stroke measuring system · clamping stroke up to 250 mm · completely encapsulated 	<ul style="list-style-type: none"> · completely encapsulated
395 ... 605 mm	application-specific	–



Tower workholding systems

Series	TS	TS TriStar	TS Vector	TS TriStar Vector
				
Data sheet Clamping jaws / Accessories	WS 4.3301 WS 4.330-Z	WS 4.3302 WS 4.330-Z	WS 4.3301 WS 4.330-Z	WS 4.3302 WS 4.330-Z
Jaw widths (max. clamping force)	100 mm (25 kN) 125 mm (40 kN)	80 mm (20 kN) 100 mm (25 kN) 125 mm (40 kN)	100 mm (25 kN) 125 mm (40 kN)	100 mm (25 kN) 125 mm (40 kN)
Operation mechanical	mechanical	mechanical	mechanical	mechanical
hydraulic	–	–	on request	–
Clamping principle	clamping against the fixed jaw	clamping against the fixed jaw	clamping against the fixed jaw	clamping against the fixed jaw
Application	manual loading	manual loading	manual loading / automation	manual loading / automation
Machining centre	horizontal	horizontal	horizontal	horizontal
Special features/ Options	<ul style="list-style-type: none"> · patented guide and sealing system · with 4 clamping sides - 4 x 90° · operation with 1 spindle per side · with 3rd-hand function 	<ul style="list-style-type: none"> · patented guide and sealing system · with 3 clamping sides - 3 x 120° · operation with 1 spindle per side · with 3rd-hand function 	<ul style="list-style-type: none"> · patented guide and sealing system · with 4 clamping sides - 4 x 90° · operation with 2 spindles (transmission of different clamping forces) · with central fixed jaw or 2 x fixed jaw 	<ul style="list-style-type: none"> · patented guide and sealing system · with 3 clamping sides - 3 x 120° · operation with 2 spindles (transmission of different clamping forces) · with central fixed jaw or 2 x fixed jaw
Overall heights	562 / 707 mm	248 ... 707 mm	599 ... 750 mm	599 ... 750 mm



Accessories

Clamping jaws

Clamping jaws have a great influence on the clamping quality and safety and thus also on the machining results.

We offer a large catalogue range of clamping jaws for each clamping system.

If you do not find the desired clamping jaw in our catalogue range, please contact us. Besides the catalogue range, we also manufacture customised clamping jaws. We would be pleased to advise you on the selection of optimum clamping jaws.

- Clamping jaws with or without jaw inserts
- Clamping jaws, extra wide or extra high
- Step jaws
- Reversible jaws/reversible step jaws
- Step jaw inserts
- Block jaws
- Vee jaws
- Pendulum jaws
- Central jaws, fix or floating
- QIS clamping jaw system
- SlimFlex clamping jaw system
- Special grip jaws
- Clamping modules for multiple clamping systems

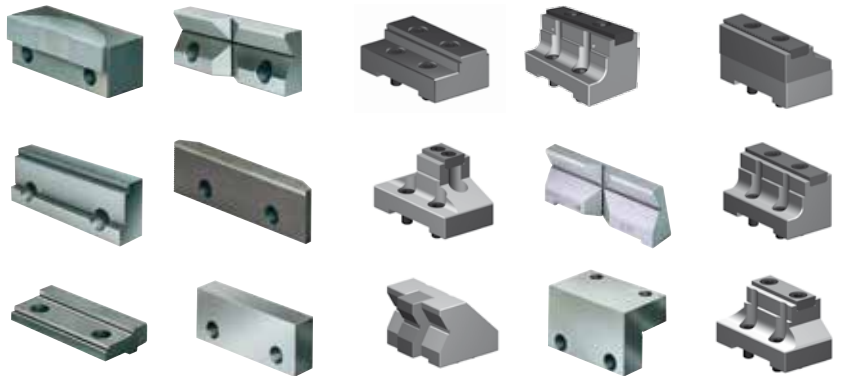

Jaw inserts

Jaw inserts allow the clamping of blanks and finished parts with the same clamping jaws or the same clamping system.

An overview of jaw inserts with application recommendations is shown on data sheet WS-12-SE.

Jaw inserts
grip serrated



Jaw inserts
with coatings

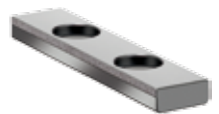

Clamping power units

For the hydraulic supply and control of hydraulic clamping systems, we offer the suitable clamping power units. Completely equipped with the necessary electrical and hydraulic control, the desired operating element such as hand panel or foot switch as well as the integration into the machine control.

Dependent on the application and the desired functions, we select the suitable clamping power unit for you. Please contact us.



Rapid change block Quintus

The rapid change block Quintus is used to fix the workholding systems for 5-axis machining on the machine table, alternatively with or without integrated mechanical STARK zero point clamping system "SPEEDY metec". It ensures a good accessibility of the machining tools to the workpiece.

See data sheet WS 5.6150

Rapid change block Quintus
without zero point clamping
system



Rapid change block Quintus
with zero point clamping system



Other accessories

- Clamping claws
- T-nuts
- Workpiece stops
- Angle drives
- Clamping force preselection
- Torque wrenches



**Elements and systems
for production engineering**



Römheld GmbH

Friedrichshütte
Römheldstraße 1-5
35321 Laubach
Germany
Tel.: +49 6405/89-0
Fax: +49 6405/89-211
E-mail: info@roemheld.de
www.roemheld-group.com

**Workholding systems and standard fixtures
for metal cutting and non-cutting manufacturing**



Hilma-Römheld GmbH

Schützenstraße 74
57271 Hilchenbach
Germany
Tel.: +49 2733/281-0
Fax: +49 2733/281-169
E-mail: info@hilma.de
www.roemheld-group.com

Magnetic clamping systems



Römheld Rivi GmbH

Schützenstraße 74
57271 Hilchenbach
Germany
Tel.: +49 2733/281-100
Fax: +49 2733/281-102
E-mail: info@roemheld-rivi.de
www.roemheld-group.com

Intelligent zero point clamping systems



Stark Spannsysteme GmbH

Römergrund 14
6830 Rankweil
Austria
Tel.: +43 5522/374 00-0
Fax: +43 5522/374 00-700
E-mail: info@stark-inc.com
www.stark-inc.com